



PS Laptop Management Cart with pre-installed Cat 6 Ethernet cables

**ERGOTRON®**

**PowerShuttle® (PS) Laptop Management Cart**  
**PowerShuttle (PS) Laptop Charging Cart**

**Highlights**

**Universal Design**

- Open-architecture design works with laptops, netbooks and tablets with displays up to 15.6". Maximum device size 15.1"W x 11"D x 1.69"H (38,4 x 28 x 4,3 cm)
- Country-specific power strip is provided to plug in 20 AC adapters. Unique, flexible design accommodates a variety of brick and plug styles for laptops, netbooks and tablets that won't fit in standard outlet strips

**PowerShuttle® Technology**

- Efficiently scans the system and distributes power to optimize total charge time for the laptops and prevent overloading electrical circuits at the same time

**Durable, Secure Storage**

- Robust key and lock assembly keeps devices secure. Double-hinged, locking steel front doors with recessed handle open 180° to reveal notebook storage shelves
- Rugged steel frame construction, steel front and rear doors, and molded fire-rated ABS exterior withstands heavy use of classroom settings
- For user and equipment safety, the entire cart is tested and certified to UL 60950 and 1667 standards
- Secure back compartment provides IT access to power brick storage and power strips. Clean, neat cable management runs power to units

**Easy to Use**

- Lightweight, up to 49% smaller than competitive product, this compact cart design makes it easy to safely move from room to room
- Ships fully assembled
- Four 4" (10 cm) medical-grade, dual-wheel locking casters allow easy push/pull mobility



**Charges. Manages.**  
**Compact, secure and cost-effective design.**

Buying the right laptops is only one piece of the puzzle. Securely storing, deploying and managing those important assets while making it easy for staff is equally important. This cart's universal interface charges and manages software on up to 20 devices (works with laptops, netbooks and tablets). Patented PowerShuttle Load Sensing Technology optimizes total charge time while safely preventing electrical circuit overload by efficiently grouping the number of devices that are charged at one time. Works in any environment, including education, healthcare and enterprise applications.

**JUST  
 STAND  
 .ORG**



PS Laptop Management Cart (switch not included)



**CERTIFICATION**

UL 60950 Safety of Information Technology Equipment, CAN/CSA C22 2 No. 60950

UL 1667 Tall Institutional Carts for use with Audio, Video and Television Type Equipment

ICES-003 Issue 4, Class A

FCC Part 15 Class A

Country-specific certification as required

RoHS and Reach compliant material used

- Maximum device size: 15.1" W x 11.0" D x 1.69" H (38,4 x 28 x 4,3 cm)
- Maximum device weight: ≤ 6.5 lbs (2,9 kg)

**PowerShuttle Technology**

- Efficient charging system uses Ergotron's innovative patent-pending PowerShuttle Technology to automatically optimize total charge time for up to 20 laptops or mobile devices
- Cart is powered using one country-specific power cord (12.5', 3,8 m) plugged into a wall outlet. Cord wrap is recessed into side of cart
- Never waste time charging an empty set of slots
- Safely prevents overloading electrical circuits by efficiently grouping the number of devices that are charged at one time
- LED status indicators provide users with zone charging status
- How it works: When the cart is plugged in, the system automatically measures and stores the current draw of the external outlet and the power strips inside the cart (5 devices per power strip). Max wall current is 12A for 100-120V countries and 8A for 220-240V countries. The PowerShuttle subtracts the current for the always-on devices (auxiliary outlets) from the max wall current. This leaves the amount of current available for the power strips. PowerShuttle then groups the power strips in the minimum number of groups for charging without exceeding the max wall current
- LED status indicators provide users with power distribution status
- Power (North America/Japan): 100-120V ~ 50/60Hz, 12A
- Power (UK, Europe, Australia, and China): 220-240V ~ 50/60Hz, 8A

**Compact Size**

- Lightweight; up to 49% smaller than competitive product, this compact cart design makes it easy to safely move from room to room

**Durable, Secure Storage**

- Robust two-point key and lock assembly keeps devices secure. Double-hinged, locking steel front doors open 180° to reveal storage shelves
- Rugged steel frame construction, steel front and rear doors, and molded fire-rated ABS exterior withstands heavy use of classroom settings
- Separate top and back storage compartments provide IT access to power brick storage
- Four 4" (10 cm) locking medical grade, dual wheel casters

**Additional Features PS Laptop Cart Only**

- Twenty (20) pre-installed CAT 6 RJ4S Ethernet cables enable remote management of laptops for software updates via Wake On LAN (with customer supplied Ethernet switch)
- Mounting brackets and country-specific internal auxiliary outlet for switch and WAP power

- Laptop Management Cart includes external auxiliary outlet (2 receptacles for North America/ Japan, 1 for all other countries). Power is continuous to these outlets when in use
- Five (5) 12V DC continuous operating fans are included to keep equipment cool during the management process. Not needed for charge-only
- Built-in temperature sensor protects your equipment by shutting down charging activity if the maximum internal cart temperature is exceeded. Charging activity will resume automatically once temperature returns to safe levels

<b>Product Name (color)</b>	PS Laptop Management Cart (black)	PS Laptop Charging Cart (black)
	24-246-085 US/CA/MX	24-291-085 US/CA/MX
<b>Part number</b>	24-247-085 China	24-292-085 China
	24-248-085 Japan	24-293-085 Japan
	24-249-085 UK/SNG/HK	24-294-085 UK/SNG/HK
	24-250-085 EU	24-295-085 EU
	24-251-085 AU/NZ	24-296-085 AU/NZ
<b>Product Includes</b>	20 device slots, 12.5' (3,8 m) power cable, country-specific power strip, cable management tray, four 4" medical-grade locking casters, integrated handle	
<b>Additional Features</b>	20 CAT 6 Ethernet cables, standard 1U Ethernet switch mounting brackets, auxiliary outlet (external), auxiliary outlet (internal for switch and WAP)	One (1) 12V DC continuous operating fan in top compartment
	Five (5) 12V DC continuous operating fans Built-in temperature sensor	
<b>Product Dimensions</b>	28.0" W x 24.4" D x 40.0" H (71,1 x 62.0 x 101,6 cm)	
<b>Shipping Dimensions</b>	32.7" W x 27.6" D x 46.4" H (83 x 70,2 x 117,9 cm)	
<b>Product Weight</b>	157 lbs (71 kg)	146 lbs (66,2 kg)
<b>Shipping Weight</b>	214 lbs (97,1 kg)	203 lbs (92,1 kg)
<b>Warranty</b>	Five (5) years; two (2) years for power module; one (1) year for other electrical components	

© 2015 Ergotron, Inc. rev. 01/20/2015/EA Literature made in US  
Content is subject to change without notification

**Americas Sales and Corporate Headquarters**

St. Paul, MN USA  
(800) 888-8458  
+1-651-681-7600  
www.ergotron.com  
sales@ergotron.com

**EMEA Sales**

Amersfoort, The Netherlands  
+31 33 45 45 600  
www.ergotron.com  
info.eu@ergotron.com

**APAC Sales**

Tokyo, Japan  
www.ergotron.com  
apaccustomerservice@ergotron.com

**Worldwide OEM Sales**

www.ergotron.com  
info.oem@ergotron.com





COAST Wholesale  
APPLIANCES

**BOSCH**

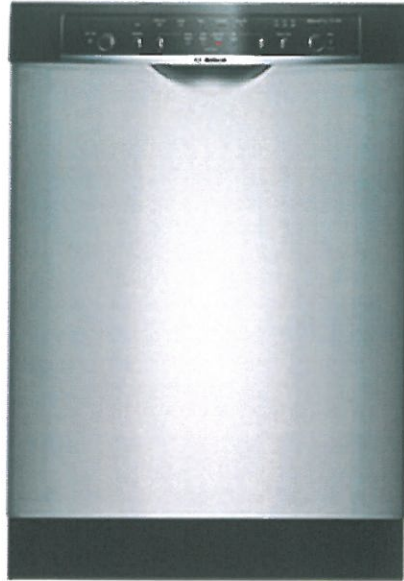

**Bosch Full Console Dishwasher**  
Model# SHE3AR55UC

**Feature:**

14-Place Settings  
4 Wash Cycles  
2 Options  
Sanitize Option  
Delay Start  
Standard Racks  
50 dBA  
Stainless Steel

**Dimensions**

Width : 23 9/16"  
Depth : 22 9/16"  
Height : 33 7/8"

*Dimensions to be used for preliminary planning only not for construction purposes. Please visit our website for detailed and up to date features and dimensions at [www.coastappliances.com](http://www.coastappliances.com)*





COAST Wholesale  
APPLIANCES

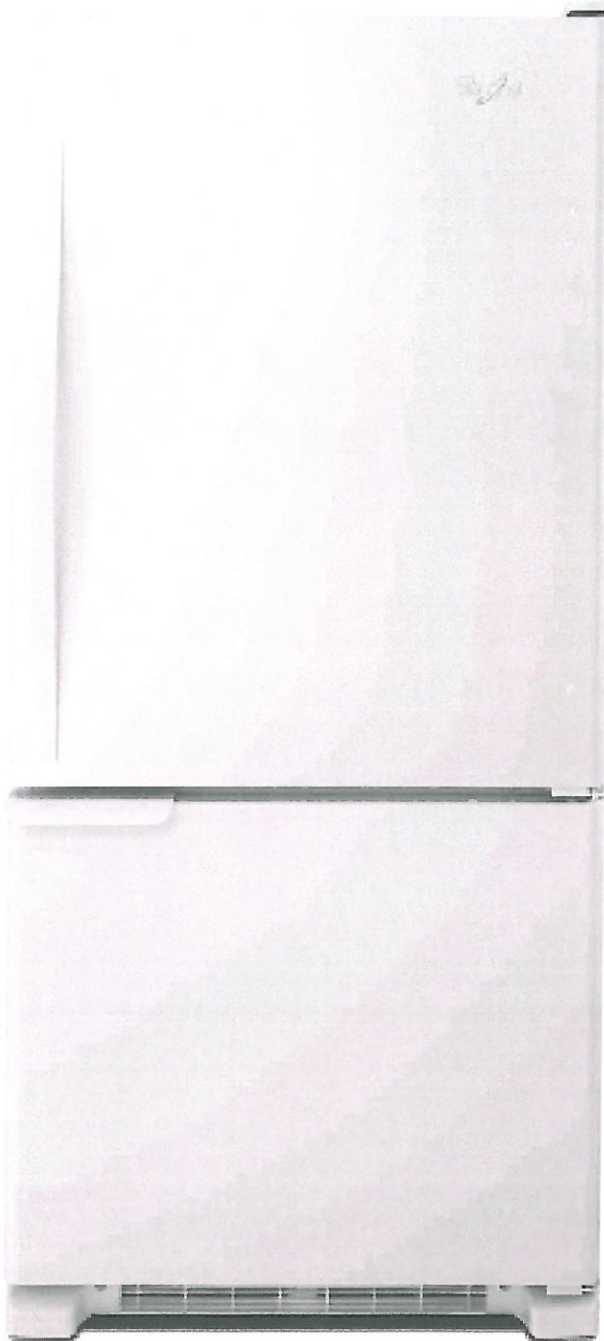

**Features:**

Accu-Chill™ Temperature Management System  
SpillGuard™ Glass Shelves  
Adaptive Defrost  
LED Interior Lighting  
FreshFlow™ Produce Preserver  
18.7 Cu Ft Capacity

**Dimensions:**

Height: 67"  
Width: 29 3/4"  
Depth: 33 3/8"

**Whirlpool Bottom-Mount Refrigerator**

Model# WRB119WFBW

*Dimensions to be used for preliminary planning only not for construction purposes. Please visit our website for detailed and up to date features and dimensions at [www.coastappliances.com](http://www.coastappliances.com)*





COAST Wholesale  
APPLIANCES

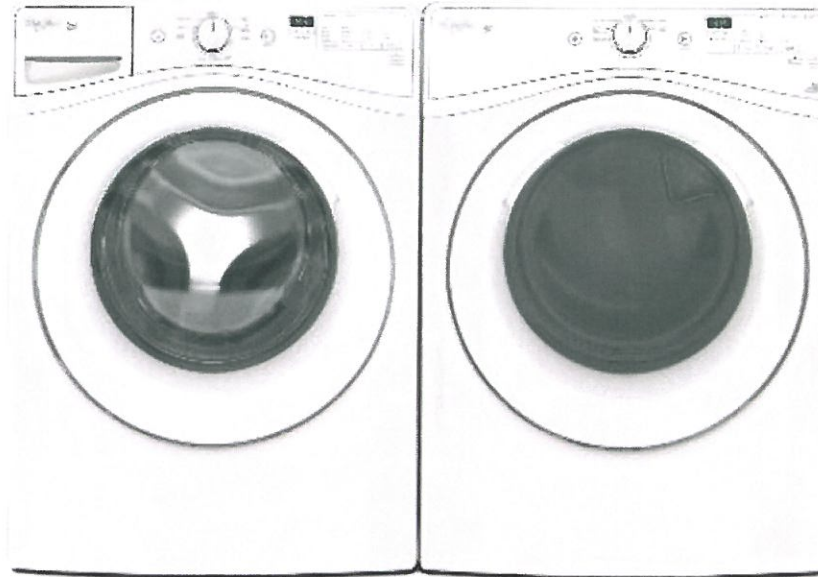

### **Whirlpool 27" Front-Load Washer**

Model# WFW72HEDW

**Features:**

- 4.2 Cu Ft Capacity
- 4 Temperature Selections
- 8 Cycle Settings
- Smooth Stainless Steel Wash Basket

**Dimensions:**

- Width: 27"
- Depth: 33 1/8"
- Height: 39 3/4 "
- Depth With Door Open 90°: 52 3/4"
- Minimum Height 38 3/4"
- Maximum Height 39 3/4"

### **Whirlpool 27" Front-Load Dryer**

Model# YWED72HEDW

**Features:**

- 7.4 Cu Ft Capacity
- 4 Temperature Selections
- 6 Cycle Settings
- Moisture Sensor

**Dimensions:**

- Width: 27"
- Depth: 31"
- Height: 38 3/4"
- Depth With Door Open 90°: 51"
- Minimum Height: 38 3/4"
- Maximum Height: 39"

*Dimensions to be used for preliminary planning only not for construction purposes. Please visit our website for detailed and up to date features and dimensions at [www.coastappliances.com](http://www.coastappliances.com)*





**COAST Wholesale  
APPLIANCES**

*"Innovative Products for Builders, Designers & Home Owners"*

**Panasonic®**

**Microwave  
NNST681S**



**DIMENSIONS:**

310 x 525 x 401 mm / 12.20" x 20.67" x 15.79"

*Dimensions to be used for preliminary planning only not for construction purposes. Please visit our website for detailed and up to date features and dimensions at [www.coastappliances.com](http://www.coastappliances.com)*

Convenient 5 Button Control Panel  
1.2 cu ft.

1200 W output power

Sensor reheat

Sensor cook with instant access buttons  
(5 categories)

Inverter® Turbo Defrost

Popcorn key

Keep Warm

Quick Minute

Child Safety Lock

Optional trim kit available

Exterior dimensions

Color: Stainless Steel with Black Accents



T5

## The Cleaning Professional's Scrubber

- Achieve 100% solution recovery – even on 180 degree turns – with superior squeegee design
- Quietly clean with a true, OSHA-recognized test-standard 67 dBA
- Increase safety with FaST™ foam scrubbing, NFSI-certified to increase floor traction 21%

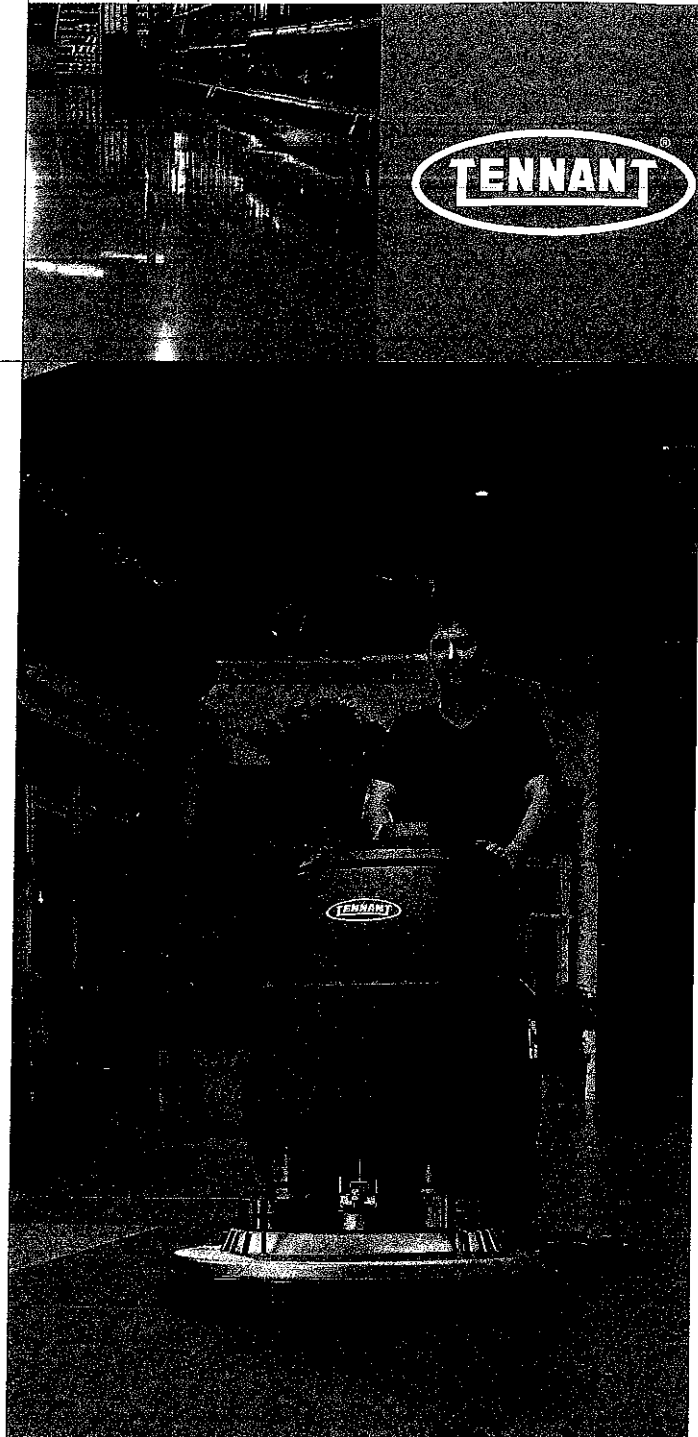

**FaST**  
Foam Scrubbing Technology

The Safe Scrubbing Alternative®

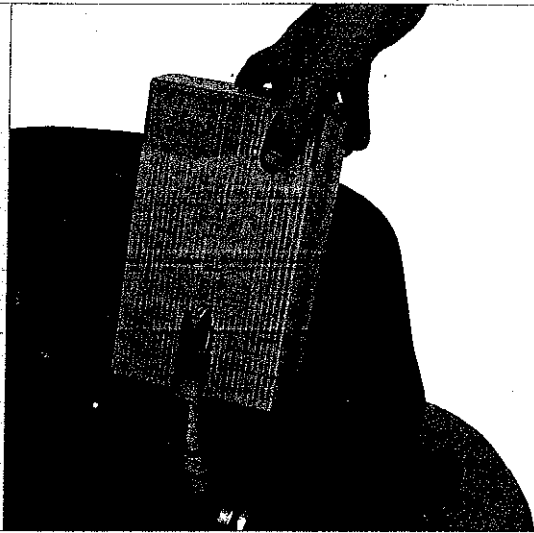

## GENUINE TENNANT PARTS, SUPPLIES & SERVICE

### Foam-based FaST: the Key to Peak Productivity and Safety

Using an innovative foam-based detergent delivery system, scrubbers with FaST increase productivity, eliminate the need for operators to handle chemicals, and leave just-cleaned floors virtually dry and safe for traffic.

### Genuine Tennant Parts Advantage

Operate your machine with confidence by choosing genuine Tennant parts. Only authentic Tennant parts are engineered in conjunction with Tennant equipment. For years of worry-free operation, accept only genuine parts and supplies.

### Industry's Only Factory-Direct Service Network

Tennant offers the only factory-trained, locally based network of 400+ service techs dedicated to keeping your cleaning program up and running.

*Choose Tennant Financial for simple, quick financing with flexible upgrade options, and no long-term obligations.*



**Certified by the NFSI, FaST increases floor traction up to 21%.**

## T5 WALK-BEHIND FLOOR SCRUBBER

FEATURES	Disk	Cylindrical
<b>Scrubbing System</b>		
Cleaning path	24 in / 600 mm 28 in / 700 mm 32 in / 800 mm	26 in / 650 mm 32 in / 800mm
Solution tank capacity	22.5 gal / 85 L	22.5 gal / 85 L
<b>Productivity (per hour)</b>		
Theoretical max	(24 in) 26,400 ft <sup>2</sup> / 2,500 m <sup>2</sup> (28 in) 30,800 ft <sup>2</sup> / 2,900 m <sup>2</sup> (32 in) 35,200 ft <sup>2</sup> / 3,300 m <sup>2</sup>	(26 in) 28,600 ft <sup>2</sup> / 2,700 m <sup>2</sup> (32 in) 35,200 ft <sup>2</sup> / 3,300 m <sup>2</sup>
Estimated actual* (conventional)	(24 in) 17,875 ft <sup>2</sup> / 1,660 m <sup>2</sup> (28 in) 20,800 ft <sup>2</sup> / 1,900 m <sup>2</sup> (32 in) 24,000 ft <sup>2</sup> / 2,200 m <sup>2</sup>	(26 in) 19,200 ft <sup>2</sup> / 1,790 m <sup>2</sup> (32 in) 24,000 ft <sup>2</sup> / 2,200 m <sup>2</sup>
Estimated actual* (FaST)	(24 in) 20,075 ft <sup>2</sup> / 1,900 m <sup>2</sup> (28 in) 22,750 ft <sup>2</sup> / 2,100 m <sup>2</sup> (32 in) 26,250 ft <sup>2</sup> / 2,400 m <sup>2</sup>	(26 in) 21,000 ft <sup>2</sup> / 2,000 m <sup>2</sup> (32 in) 26,250 ft <sup>2</sup> / 2,400 m <sup>2</sup>
<b>Recovery System</b>		
Scrub motors	(2) 0.75 hp / 0.56 kW	(2) 0.63 hp / 0.47 kW
Scrub motor speed	220 rpm	1500 rpm
Brush/pad down pressure	(3 settings) 40, 80 and 120 lb / 18, 36 and 54 kg	
Recovery tank capacity (includes demisting chamber)	27 gal / 102 L	
Vacuum motor	0.85 hp / 0.64 kW, 3-stage	
Waterlift	62 in / 1,570 mm	
<b>Propelling &amp; Power System</b>		
Propel speed (variable to)		
Transport	2.7 mph / 4.3 km/h	
Scrubbing	2.5 mph / 4.0 km/h	
Batteries – 24 V system (4x 6 V batteries), charger included		
Standard run time**	6 V, 235 Ah / up to 5.5 hours	
Optional gel run time**	6 V, 200 Ah / up to 4.5 hours	
Gradeability (ramp climb)		
Scrubbing/transporting (full)	3.0° / 5.0°	
Trailer ramps (empty)	11°	
<b>Dimensions/Weights</b>		
Product length		
	(24 in) 52.9 in / 1,340 mm (28 in) 55.7 in / 1,410 mm (32 in) 58.4 in / 1,480 mm	(26 in) 55.4 in / 1,410 mm (32 in) 55.4 in / 1,410 mm
Product width (scrub head)		
	(24 in) 25.4 in / 640 mm (28 in) 29 in / 740 mm (32 in) 33 in / 840 mm	(26 in) 28 in / 710 mm (32 in) 34 in / 860 mm
Squeegee width		
	(24 in) 35.7 in / 910 mm (28 in) 41.3 in / 1,050 mm (32 in) 46.6 in / 1,180 mm	(26 in) 41.3 in / 1,050 mm (32 in) 46.6 in / 1,180 mm
Product height		
	44 in / 1,120 mm	
Product weight (with batteries)		
	(24 in) 580 lb / 263 kg (28 in) 609 lb / 276 kg (32 in) 621 lb / 282 kg	(26 in) 621 lb / 282 kg (32 in) 629 lb / 285 kg
Sound level*** (operator's ear)		
	67 dBA	68 dBA
<b>Warranty</b>		
10/3/3	3 years / 2,500 hours on parts and labor (excluding batteries). 10 years on rotationally-molded polyethylene tanks.	

\* Estimated coverage rates use the practical speed and empty/fill time standards from the 2004 ISSA Cleaning Times handbook.

\*\* Run times are based on continuous scrubbing run times.

\*\*\* Sound levels per ISO 11201 as recommended by the American Association of Cleaning Equipment manufacturers & OSHA.

## SEEING IS BELIEVING

See for yourself how the T5 scrubber can help you reach a higher standard of cleanliness and safety in your facility. For a demonstration or additional information, call 800.553.8033.



VACUUM.

**SUGGESTIONS FOR WRITING BID SPECIFICATIONS ON THE  
ADVANCE VL500™ 55 or 75**

<b>GENERAL</b>	Machine shall be the type described as a commercial duty, tank style vacuum for use in both wet and dry applications. The tank capacity shall be 14 gallons (55 L) or 19 gallons (75 L).												
<b>MOTOR</b>	The motor shall have a maximum power of 1,100 W and operate at 120 V / 60 Hz. The motor head shall be hinged for easy, no-tools, removal.												
<b>MAIN HANDLE AND TROLLEY</b>	Shall be a fixed stainless steel push handle or an adjustable, folding, push handle with an integrated hanger for power cable storage. Machine tank and motor shall be easily lifted off the trolley with no tools for simple machine maintenance.												
<b>AIRFLOW + VACUUM</b>	Shall be 101 CFM (48 L/sec) and 72 inches of H <sub>2</sub> O (18 kPa).												
<b>SUCTION POWER</b>	The machine shall have a suction power of 185 W or more at the end of the vacuum tube.												
<b>FILTRATION</b>	The filtration system shall include a single filter set used in both wet and dry applications. The filter set shall include a high capacity cartridge filter that is waterproof, washable, and seals the motor head to ensure full motor protection from debris and liquids. The cartridge filter shall have a minimum filtration area of 683 in <sup>2</sup> (4,410 cm <sup>2</sup> ). The wet filter shall be designed to dissipate foam and have a minimum filtration area of 285 in <sup>2</sup> (1,840 cm <sup>2</sup> ). The filter system shall be a locking stack system to ensure proper alignment and optimum airflow through the vacuum system.												
<b>TANK EMPTY AND CAPACITY</b>	The tank and frame shall include a weight distribution mechanism that allows users to easily dump a full tank without user strain. The machine shall include a drain hose and spout for simple tip-and-pour options to empty the tank. The tank capacity shall be 14 gallons (VL500-55) or 19 gallons (VL500-75).												
<b>SQUEEGEE</b>	Shall include a break-away squeegee system with a simple foot-pedal engagement mechanism.												
<b>BASE</b>	Shall be designed with a wide stance to ensure maneuverability even when the tank is full.												
<b>TOOLS/ ACCESSORIES</b>	Shall have as standard onboard a hose, extension tube, crevice tool, floor nozzle with rubber strip, brush tool, and an optional squeegee kit. The machine shall have integrated tools storage for ease of use and simplified transportation.												
<b>POWER CABLE</b>	Shall be 50 feet (15 m) in length.												
<b>WEIGHT</b>	Shall be 52 pounds (23.5 kg) for the VL500-55 and 61 pounds (27.5 kg) for the VL500-75.												
<b>DIMENSIONS</b>	Shall not exceed: <table><thead><tr><th></th><th><u>VL500-55</u></th><th><u>VL500-75</u></th></tr></thead><tbody><tr><td>Width:</td><td>24 inches (62 cm)</td><td>24 inches (62 cm)</td></tr><tr><td>Length:</td><td>34 inches (84 cm)</td><td>26 inches (66 cm)</td></tr><tr><td>Height:</td><td>40 inches (100 cm)</td><td>41 inches (103 cm)</td></tr></tbody></table>		<u>VL500-55</u>	<u>VL500-75</u>	Width:	24 inches (62 cm)	24 inches (62 cm)	Length:	34 inches (84 cm)	26 inches (66 cm)	Height:	40 inches (100 cm)	41 inches (103 cm)
	<u>VL500-55</u>	<u>VL500-75</u>											
Width:	24 inches (62 cm)	24 inches (62 cm)											
Length:	34 inches (84 cm)	26 inches (66 cm)											
Height:	40 inches (100 cm)	41 inches (103 cm)											

**THE MACHINE SHALL BE AN ADVANCE VL500™ 55 or VL500™ 75.**

# Advance AquaClean® 16ST/16XP/18FLX

Carpet Extractors

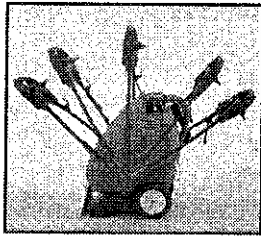

The AquaClean® 18FLX has dual operating modes for traditional pull back or high productivity walk-behind extraction.

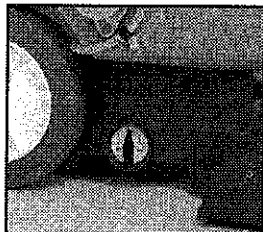

16XP and 18FLX have dual moisture modes for low moisture/ high productivity cleaning or deep restorative cleaning.



Carpet extraction and spotting/ upholstery machine in one with integrated hand tool on the 16XP and 18FLX.

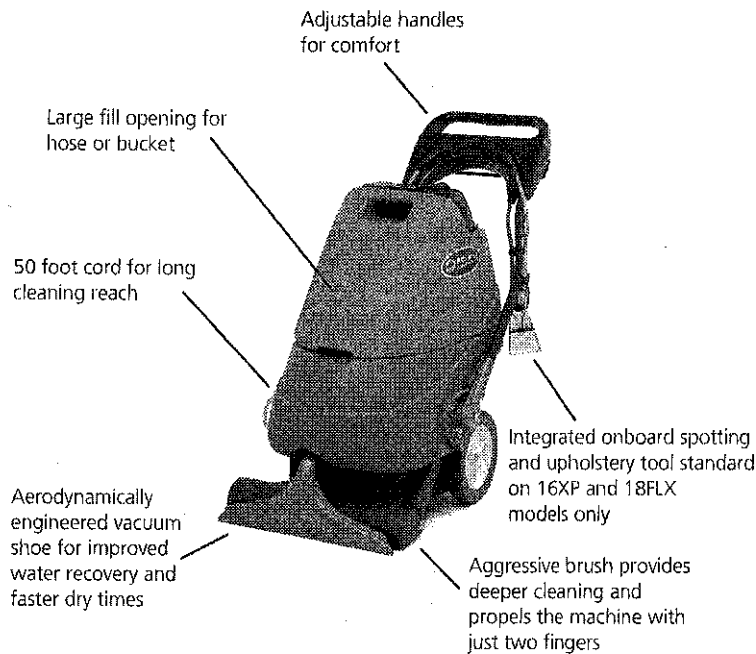

## Defining Cleaning Innovation...

- Our products are designed using innovative technology that increases productivity and drives down the cost to clean.
- You can get expert service and maintenance for your Advance machines from factory-trained personnel around the world. Fast parts delivery, too.
- Maintain peak performance with Nilfisk-Advance Parts.

## Technical Specifications

Models	16ST	16XP	18FLX
Solution Tank	8 gal (30.3 L)	8 gal (30.3 L)	11 gal (41.6 L)
Recovery Tank	6 gal (22.7 L)	6 gal (22.7 L)	9 gal (34.1 L)
Flow Rate DCM Mode	N/A	0.33 gpm @ 60 psi	0.33 gpm @ 60 psi
Flow Rate Rest. Mode	0.7 gpm @ 60 psi	0.7 gpm @ 60 psi	0.7 gpm @ 60 psi
Vacuum Motor	1.5 hp, 3 stage	1.5 hp, 3 stage	1.5 hp, 3 stage
Brush Motor	1/3 hp	1/3 hp	1/3 hp
Brush Size / Cleaning Path	16 in (40.6 cm)	16 in (40.6 cm)	18 in (45.7 cm)
Vacuum Shoe	18 in (45.7 cm)	18 in (45.7 cm)	20 in (45.7 cm)
Power Cable	50 ft (15 m) Fixed	50 ft (15 m) Detachable	50 ft (15 m) Detachable
Waterlift	117 in (297 cm)	117 in (297 cm)	117 in (297 cm)
Weight			
Net	94 lb (42.64 kg)	100 lb (45.36 kg)	110 lb (49.90 kg)
Shipping	120 lb (54.43 kg)	126 lb (57.13 kg)	180 lb (81.65 kg)
Part Numbers	56265003	56265000	56265001

Specifications are subject to change without notice.



14600 21st Avenue North  
Plymouth, MN 55447-3408  
www.advance-us.com  
Phone: 800-850-6559  
Fax: 800-989-6566

240 Superior Boulevard  
Mississauga, Ontario, Canada L5T 2L2  
www.nilfisk-advance.ca  
Phone: 905-564-1149 or 800-668-8400  
Fax: 905-564-1030 or 800-263-5111

©2012, Nilfisk-Advance, Inc.,  
Printed in U.S.A., Form L1677A, 10-12



Search by keyword, product code...



CALL 1-800-723-4000

View cart  
(0 items): **Sub-total: \$0.00**



- [Binding](#)
- [Laminating](#)
- [Shredding](#)
- [Cutting](#)
- [Paper Handling](#)
- [Service](#)
- [Customize](#)
- [Reconditioned Equipment](#)

Home / Laminating / Equipment / Roll Laminators / Desktop / GBC® HeatSeal® Pinnacle 27 EZload® Thermal Roll Laminator, NAP I/II, 27" Max. Width, 6 Min Warm-Up [Sign In](#) [Product Registration](#)

## GBC® HeatSeal® Pinnacle 27 EZload® Thermal Roll Laminator, NAP I/II, 27" Max. Width, 6 Min Warm-Up

Thermal roll laminator with EZload simplifies film loading and provides quick and easy laminating. Warms up in just 6-9 minutes to laminate items up to 27" wide with NAP I or II film up to 3 mil thick. Built-in horizontal trimmer helps you turn out clean and polished lamination every time and the control panel includes a handy footage counter.

**1701720EZ**

**Call for a quote 1-800-723-4000**

[Compare \(up to 4\)](#)

- [Features](#)
- [Specifications](#)
- [Resources](#)

- Thermal roll laminator with EZload technology eliminates film loading mistakes
- Use with Pinnacle 27 EZload Roll Film up to 3 mil thick
- 6 to 9 minute warm-up time
- Variable speed, laminates up to 12' per minute
- 27" maximum document width
- Additional features include audible alerts, footage counter, temperature readout, auto shutoff and motorized reverse
- Limited 1-year warranty
- 21" x 35.75" x 13.5"



Share this page 8+



**GBC® Pinnacle 27 EZload® Roll Laminator**  
[Watch video](#)



**GBC® Pinnacle 27 EZload™ How to Load Video**  
[Watch video](#)



**GBC® Pinnacle 27 Roll EZload™ Laminator**  
[Watch video](#)

**Related Products**

**Accessories & Supplies**



GBC® HeatSeal® Pinnacle 27 Thermal Roll Laminator, NAP I/II, 27" Max. Width, 6 Min Warm-Up



GBC® Ultima® 35 EZload® Thermal Roll Laminator, 12" Max. Width, 1 Min Warm-Up

# Trade West Equipment Ltd

## Bulman R999 Eight Roll Vertical Paper Rack



Eight Roll Vertical Paper Racks. Designed for use wherever larger quantities of paper are required. The R999 holds eight 9" diameter rolls 36" in width and occupies only 25" x 48½" of floor space and stands 47 1/2" high. Mounted on four strong, smoothly rolling casters, the unit can be positioned and locked in place with integral caster wheel locks for safety and stability. Bulman Vertical Racks incorporate an automatic blade locking device for easy roll changing and spring-loaded blades for sure cutting. Welded steel construction and strong functional design assure durable, long wear life. Finished in attractive gray baked powder coat.

### Features

- **Warranty: 1 Year**
- **Weight: 67 pounds**
- **Number of Rolls: 8**
- **Paper Roll Max.: 36"L**



Business Solutions

English

G

[Home](#) [Products & Services](#) [Support](#) [Sales/Service Locator](#) [About](#) [News](#) [Environment](#) [Careers](#)

You are here: [Canada](#) [Business Solutions](#) [Products](#) [Office Systems](#) [Monochrome MFP](#) [bizhub 364e](#)

## Monochrome Multifunction Printer/Copiers

[Business Solutions](#)

[Products](#)

[Office Systems](#)

[Colour MFP](#)

[Monochrome MFP](#)

[bizhub 215](#)

[bizhub 224e](#)

[bizhub 25e](#)

[bizhub 284e](#)

[bizhub 364e](#)

[bizhub 4050](#)

[bizhub 454e](#)

[bizhub 4750](#)

[bizhub 554e](#)

[bizhub 654e](#)

[bizhub 754e](#)

[Printers](#)



### bizhub 364e

The bizhub 364e puts you in total control, with a colour display as simple to operate as a tablet -- to print and copy both colour and B&W documents at up to 160 original copies. You control the solutions your business depends on. You have security options, auto finishing and more -- everything to increase productivity.

[Request a call](#)

[Overview](#)

[Accessories](#)

[Applications](#)

#### Overview

### bizhub 364e

#### Key Features:

**B&W:** 36 ppm

**Max Paper Capacity:** 3,650 sheets

**Optional Dual Scanning:** 160 opm

**Enhanced multi-touch interface**

#### Other Features:

High-speed 36 ppm B&W print/copy output to keep ahead of rising demands

Optional dual scanning at up to 160 opm to capture originals in both colour and B&W

Built-in Emperon print system with PCL6/PS3 emulation, native XPS

Large 9" colour display -- as simple to operate as a familiar tablet

Multi-touch functions: swipe, drag, double-tap, toggle, pinch

Transparent menus, customizable icons, improved soft keyboards

Downloadable apps to make you more productive

Complies with IEEE 2600.1 international security standard

[Terms of Use](#) [Privacy Policy](#) [Sitemap](#)

[Global Site](#)

©2014 Konica Minolta Business Solutions (Canada) Ltd.



MFP

# bizhub C364e

COLOUR MID-VOLUME MULTIFUNCTION PRINTER

## bizhub C364e

Ideal for growing businesses, the bizhub C364e is a powerful, affordable colour MFP with superior Simitri HD image quality and fast 36 ppm print/copy output. Optional dual scanning at up to 160 opm brings information into your workflow faster – and enhanced touchscreen simplicity never slows you down.

### System Overview

<b>System memory</b>	2,048 MB
<b>System hard disk</b>	250 GB
<b>Interface</b>	10BASE-T/100BASE-TX/1000BASE-T Ethernet, USB 2.0
<b>Network protocols</b>	TCP/IP (IPv4/IPv6), SMB, LPD, IPP, SNMP, HTTP, HTTPS
<b>Frame types</b>	Ethernet 802.2, Ethernet 802.3, Ethernet II, Ethernet SNAP
<b>Dual scan document feeder (optional)</b>	Up to 100 originals / 5.5" x 8.5" to 11" x 17" / 35-163 gsm Reversing automatic document feeder or dual scan document feeder available
<b>Printable paper size</b>	<b>Scanning/Copying:</b> up to 11" x 17" <b>Printing:</b> up to 11" x 17" full bleed on 12" x 18" paper Custom paper sizes Banner paper 11.75" x 47.25" max
<b>Printable paper weight</b>	52-300 gsm
<b>Paper input capacity</b>	<b>Standard:</b> 1,150 sheets / <b>Max.:</b> 3,650 sheets
<b>Tray 1</b>	500 sheets / 5.5" x 8.5" to 11" x 17" / 52-256 gsm
<b>Tray 2</b>	500 sheets / 5.5" x 8.5" to 12" x 18" / 52-256 gsm
<b>Tray 3 (optional)</b>	500 sheets / 5.5" x 8.5" to 11" x 17" / 52-256 gsm
<b>Tray 4 (optional)</b>	2 x 500 sheets / 5.5" x 8.5" to 8.5" x 11" / 52-256 gsm
<b>Large capacity tray PC-410 (optional)</b>	2,500 sheets / 8.5" x 11" / 52-256 gsm
<b>Manual bypass</b>	150 sheets / 4" x 6" to 12" x 18" / custom paper sizes / 50-300 gsm
<b>Automatic duplexing</b>	5.5" x 8.5" to 12" x 18" / 52-256 gsm
<b>Finishing modes</b>	Offset, group, sort, punch, half-fold, tri-fold, booklet
<b>Output capacity</b>	<b>Max. with finisher:</b> 3,300 sheets <b>Max. without finisher:</b> 250 sheets
<b>Stapling (optional)</b>	<b>Max.:</b> 50 sheets or 48 sheets + 1 cover sheet (up to 209 gsm)
<b>Stapling output capacity</b>	<b>Max.:</b> 1,000 sheets
<b>Tri-fold</b>	Up to 3 sheets
<b>Tri-fold capacity</b>	<b>Max.:</b> 30 sheets (tray)
<b>Booklet</b>	<b>Max.:</b> 20 sheets or 19 sheets + 1 cover sheet (up to 209 gsm)
<b>Booklet output capacity</b>	<b>Max.:</b> 100 sheets (tray)
<b>Copy/print volume</b>	<b>Max.:</b> 125,000 pages/month <sup>1</sup>
<b>Toner lifetime</b>	<b>Black:</b> 27,000 pages / <b>CMY:</b> 25,000 pages
<b>Imaging unit lifetime</b>	<b>Black:</b> 120,000 pages / 590,000 pages (Drum / Developer) <b>CMY:</b> 90,000 pages
<b>Power consumption</b>	120 V / 50/60 Hz, less than 1.5 kW (system)
<b>System dimensions</b>	24.2" x 27" x 31" (W x D x H)
<b>System weight</b>	Approx. 185.18 lb

### Copier Specifications

<b>Copying process</b>	Electrostatic laser copy, tandem, indirect
<b>Toner system</b>	Simitri™ HD Polymerized Toner
<b>Print speed (8.5" x 11")</b>	<b>B&amp;W / Colour:</b> up to 36 ppm (Portrait)
<b>Print speed (11" x 17")</b>	<b>B&amp;W / Colour:</b> up to 18 ppm (Portrait)
<b>Autoduplex speed (8.5" x 11")</b>	<b>B&amp;W / Colour:</b> up to 36 ppm (Portrait)
<b>1<sup>st</sup> copy out time</b>	<b>B&amp;W:</b> 5.3 sec / <b>Colour:</b> 6.9 sec
<b>Warm-up time</b>	Approx. 20 sec <sup>2</sup>
<b>Copy resolution</b>	600 x 600 dpi
<b>Gradations</b>	256 gradations
<b>Multi-copy</b>	1-9,999
<b>Original format</b>	Up to 11" x 17"
<b>Magnification</b>	25-400% in 0.1% steps, auto zooming
<b>Copy functions</b>	Electronic sorting, multi-job adjustments (contrast, sharpness, image density), proof copy, interrupt mode, colour mode, separate scan, sort/group, combination, original selection, ID card copy 2-in-1, 4-in-1

### Printer Specifications

<b>Print resolution</b>	1800 x 600 dpi, 1200 x 1200 dpi
<b>PDL</b>	PCL 6 (xL 3.0), PCL 5c, PostScript 3 (ver. 3016), XPS
<b>Operating systems</b>	Windows (x32/x64) XP / Vista / 7 / 8 Windows Server (x32/x64) 2003 / 2008 / 2008 R2 <sup>1</sup> / 2012 <sup>2</sup> Macintosh OS X 10.2.8 or later UNIX / Linux / Citrix
<b>Printer fonts</b>	80 PCL Latin, 137 PostScript 3
<b>Print functions</b>	Direct Print of PCL, PS, TIFF, XPS, PDF, encrypted PDF files and OOXML (DOCX, XLSX, PPTX), multimedia and mixplex, "Easy Set" job programming, overlay, watermark, copy protection, carbon copy print

### Printer Specifications (optional)

<b>Print controller</b>	Embedded Fiery IC-414
<b>Memory / HDD</b>	2 GB / 160 GB
<b>PDL</b>	PostScript 3 (ver. 3019) PCL 6/5c
<b>Operating systems</b>	Windows (x32/x64) XP / Vista / 7 / 8 Windows Server (x32/x64) 2003 / 2008 / 2008 R2 <sup>1</sup> / 2012 <sup>2</sup> Macintosh OS X 10.2.8 or later

### Scanner Specifications

<b>Scan speed</b>	<b>B&amp;W / Colour:</b> up to 160 opm with optional DF-701
<b>Scan resolution</b>	<b>Max.:</b> 600 x 600 dpi
<b>Scan modes</b>	Scan-to-Email, Scan-to-SMB, Scan-to-FTP, Scan-to-Box, Scan-to-USB, Scan-to-WebDAV, Scan-to-DRWS, Network TWAIN scan
<b>File formats</b>	JPEG, TIFF, PDF, PDF/A 1a and 1b (optional), compact PDF, encrypted PDF and searchable PDF (optional), XPS, compact XPS, PPTX and searchable PPTX (optional), searchable DOCX/XLSX (optional)
<b>Scan destinations</b>	2,100 (shared with fax), LDAP support
<b>Scan functions</b>	Annotation (text/time/date) for PDF, up to 400 job programs, realtime scan preview

### Fax Specifications

<b>Fax</b>	Super G3 (optional)
<b>Transmission</b>	Analog, i-Fax, Colour i-Fax, IP-fax
<b>Resolution</b>	<b>Max.:</b> 600 x 600 dpi (ultra-fine)
<b>Compression</b>	MH, MR, MMR, JBIG
<b>Modem</b>	Up to 33.6 Kbps
<b>Destinations</b>	2,100 (single + group)
<b>Functions</b>	Polling, time shift, PC fax, receipt to confidential box, receipt to email/FTP/SMB, up to 400 job programs

### User Box Specifications

<b>Storable documents</b>	<b>Max.:</b> 3,000 documents or 10,000 pages
<b>Type of user boxes</b>	Public Personal (with password or authentication) Group (with authentication)
<b>Type of system boxes</b>	Secure Print, Encrypted PDF, Fax receipt, Fax polling, Annotation
<b>User box functionality</b>	Reprint, combination download, sending (email/FTP/SMB and fax), copy box to box

**Minuteman<sup>®</sup>**  
Excellence Meets Clean



## **Front Runner Floor Machines**

**13", 17" & 20" floor machines**

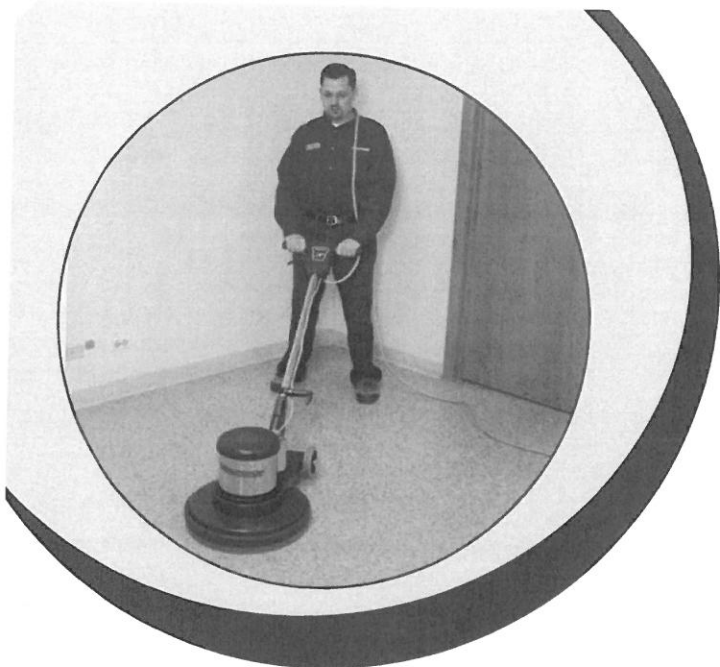

## Key Features

- Infinitely adjustable ergonomic handle
- Heavy duty frame construction
- Multiple sizes and speeds to fit all cleaning applications
- Heavy duty planetary gears for smooth operation
- Built to operate in commercial and industrial applications
- 17" and 20" machines come with pad driver at no additional cost, 13" does not come with the pad driver

## Safety

- Heavy duty 14-3 jacketed power cable designed for long wear
- Hospital grade plugs that meet all health care compliance regulations
- Safety interlock switches prevents accidental machine operation
- Heavy duty non-conductive strain relief protects operator and power cable
- Wrap-around bumper protects all environmental surroundings
- Carbon brush indicator light on two speed machines
- Power indicator light lets the operator know when the machine has power
- All operator control handles are non-conductive to protect the operator

## Markets

- Hospitality
- Institutional
- Industrial
- Health Care

## Accessories/Options

- Multiple brush grits to meet all cleaning needs
- Pad drivers
- Solution tanks

## General Overview

- Powder coated epoxy paint helps eliminate scratching and corrosion
- Large 4.5" non-marking transport wheels
- All 17" and 20" floor machines come standard with 1.5 hp, triple planetary gears
- 20" machines are available in dual speed
- 13" ¾ hp machines are available for "tight" cleaning situations
- All handles are made of tubular coated steel to resist rust and corrosion
- All machines are equipped with a 50' 14-3 wire heavy duty water resistant power cord

## Productivity

- Many types of brushes, pads and scrubbing heads are available to use on the Front Runner Floor Machines
- Heavy duty capacitor start provides the needed power even in the toughest cleaning situations
- Available in three sizes to meet all your cleaning needs
- Whether its carpets, wood floors, concrete or stone, the Front Runner series machine will help get the job done

## Ease of Use

- Infinitely adjustable handle from operator position
- Quick release cord latch
- Large non-marking 4.5" rear wheels for easy transport
- Simple safety release power switch
- Pad holder with center cup keeps pad evenly mounted

Specifications				
Model Number	M13075-00	FR17115	FR20115-2S	FR20115
Model Numb. -240V	N/A	FR17220	FR20220-2S	FR20220
Brush Diameter	13" (43 cm)	17"/43 cm	20"/51 cm	20"/51 cm
Horsepower	3/4 hp	1-1/2 hp	1-1/2 hp	1-1/2 hp
Brush Speed	175 rpm	175 rpm	160-330 rpm	175 rpm
Cable Length	50' (15 m)	50'/15 m	50'/15 m	50'/15 m
Cable Size	14-3	14-3	14-3	14-3
Wheels	3-1/2"/9 cm	4-1/2"/11 cm	4-1/2"/11 cm	4-1/2"/11 cm
Weight (with brush):	60 lbs (27 kg)	100 lbs/45 kg	103 lbs/47 kg	103 lbs/47 kg

Specifications subject to change without notice.

Minuteman International Inc  
 14N845 U.S. Route 20  
 Pingree Grove, IL 60140  
 Phone: (847) 264-5400  
 Fax: (847) 683-5207

Minuteman is a full line manufacturer of maintenance products including critical filter vacuums, industrial and commercial vacuums, sweepers, scrubbers, floor and carpet machines, PowerBoss® sweepers and scrubbers, and Parker® Litter Vacs for industrial, commercial, and institutional facilities.

A Member of the Hako Group

Come Visit our Website at  
[www.minutemanintl.com](http://www.minutemanintl.com)





## 20 cu. ft. Upright Freezer with Temperature Alarm



### 20 cu. ft. Upright Freezer with Temperature Alarm

Put a spotlight on your frozen favorites inside this 20 cu. ft. upright freezer with LED interior lighting. Activating Fast Freeze quickly drops the temperature to help lock in freshness and flavor, and the temperature alarm will notify you if the freezer gets too warm. The upright freezer prevents frost build-up for a hassle-free defrosting experience, and you can choose the ideal temperature for whatever frozen foods you're storing with electronic temperature controls. Plus, you can be sure there is plenty of ice on hand with the optional icemaker.

#### Configuration and Overview

- Freezer Type
- Upright
- Energy Star® Qualified
- CEE Tier Rating

#### Freezer Features

- Door Ajar Alarm
- Fast Freeze Setting
- Power On Indicator Light
- Defrost Drain
- Door Lock
- Defrost Type
- Automatic Defrost
- Temperature Monitor Alarm
- 33 ¼" Wide X 72" High x 27 ½" Depth
- Power: Electric CSA Rating Household

FRIGIDAIRE FEF3048LS ELECTRIC RANGE



Electrical Specifications: 240V / 208V 60Hz

Exterior Dimensions:

Height: 47 – 3/4"

Width: 29 - 7/8"

Depth: 25 – 3/4"

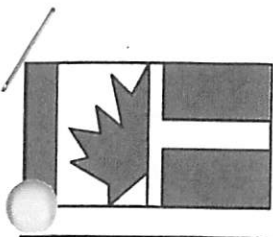

# CAN-DAN REHATEC LTD.

3-1378 Sandhill Drive,  
Ancaster, Ontario L9G 4V5

Phone: (905) 648-7522

Fax: (905) 648-7799

## Mobile Electrically Height Adjustable Change Table.

The Change Table is infinitely variable in height, within a range of approx. 16".

Powered by a 115VAC to 24VDC Actuator.

The top has a removable Grey mattress, with hook'loop fasteners on the bottom, and 2 body safety belts.

Mattress outer covering is 19oz. Qualovin Vinyl, treated for germ resistance and fire-retardant.

The table is adjustable from approx. 20" to 36".

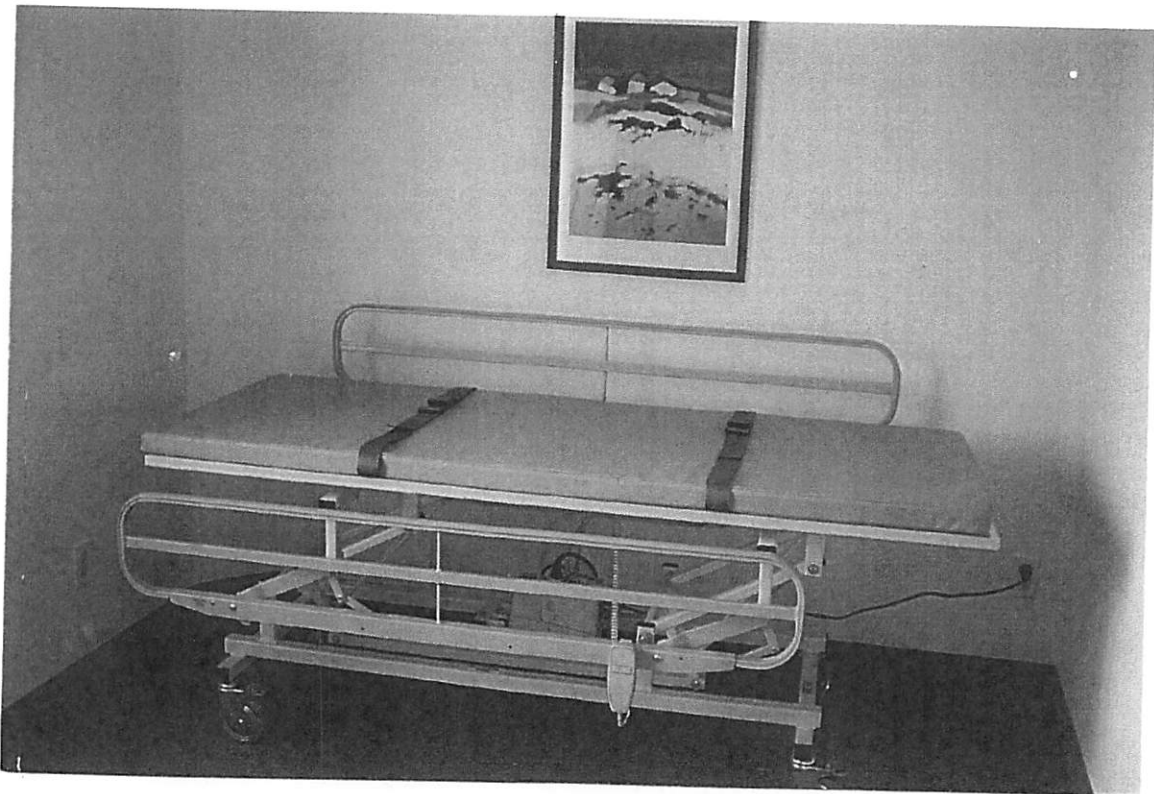

Above picture shows Change Table with optional "Side-Rails"

Model #	Size	Model #	Size	Model #	Size
19-97-62	62" x 28"	20-02-62	62" x 30"	20-03-62	62" x 32"
19-97-72	72" x 28"	20-02-72	72" x 30"	20-03-72	72" x 32"

## BE GOOD TO YOUR BACK - WHEN HELPING OTHERS.

Manufactured in Canada by Can-Dan Rehatec Ltd.

**Independent Living Inc**  
3870 Eastgate Drive  
Regina, Sk S4Z 1A5  
352-2579 1-800-667-6003

# Nicros-EasyWall™

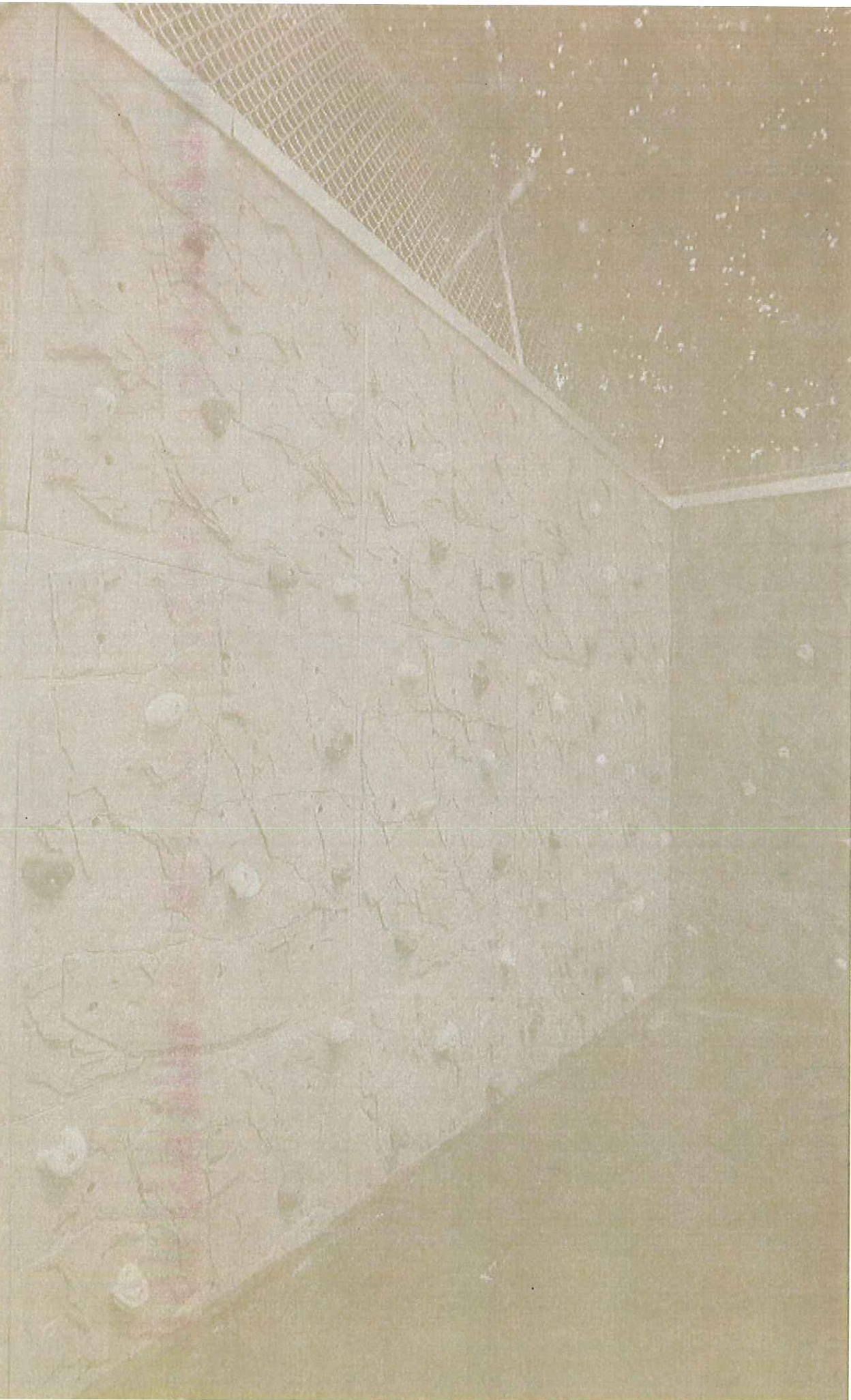

## What is Nicros-EasyWall™?

Nicros-EasyWall™ is a uniquely designed lightweight 4'x4' panel system. It is named "easy wall" because installation is as easy as bolting it to an existing wall. Each panel is two to three inches thick and also has natural crack-like features that line up with the adjoining panels, regardless of how they are oriented. This attention to detail yields a realistic and beautiful climbing wall.

The advantage to Nicros-EasyWall™ is that it's a low-cost, easy-to-install system that takes up very little space. Many schools use this product to create a bouldering wall, but it's also used in recreation centers, rehabilitation centers, health clubs, and residential properties for both bouldering walls and full-height climbing walls.

Each panel comes with five handholds to get you started but the number you'll need will depend on the climber's age and ability. The holds come in a combination of "kid-friendly" colors such as red, blue and yellow and "earth tone" colors such as tan, grey, and brown to match your panels.

The surface of Nicros-EasyWall™ panels is grippy enough that a climber can hang onto the micro-features or smear against the panel itself.

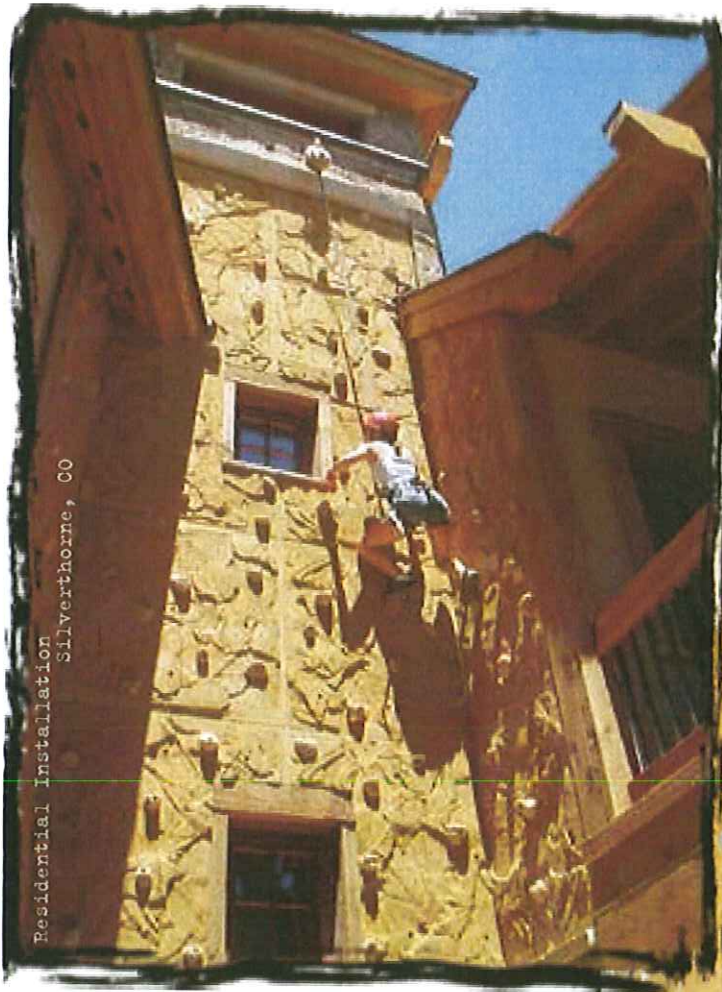

Residential Installation  
Silverthorne, CO

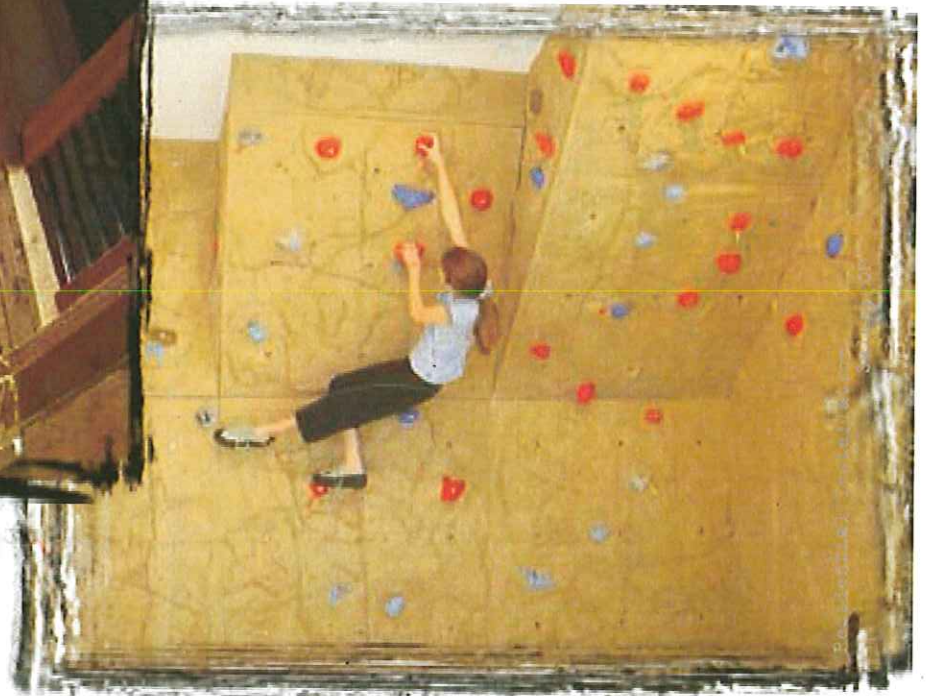

"The perfect place for putting a home training wall turned out to be the room we promised to my 13-year-old daughter. As we planned the remodel of the room, we showed our contractor Climbing Magazine's article on building your own gym. Phone calls and web-surfing quickly led us to Nicros-EasyWall™ as the most affordable and versatile choice. I designed the wall with a 22.5 inch, 45 degree overhang, and we have been having a blast ever since. We're even thinking of extending it to the other walls and ceiling of her bedroom!"

- Jenni Neahring, Residential Installation, Salem, OR

**Installation is as easy as 1, 2, 3...** Installation involves mounting Nicros-EasyWall™ panels to an existing wall such as a concrete block wall. Installation typically happens at a rate of two panels per person per hour. This means that, in less than five hours, a ten panel bouldering wall could be installed by one person! While installation is easy, it's very important that it be done correctly. We suggest consulting a licensed structural engineer to ensure correct and safe attachment of the panels to your building.

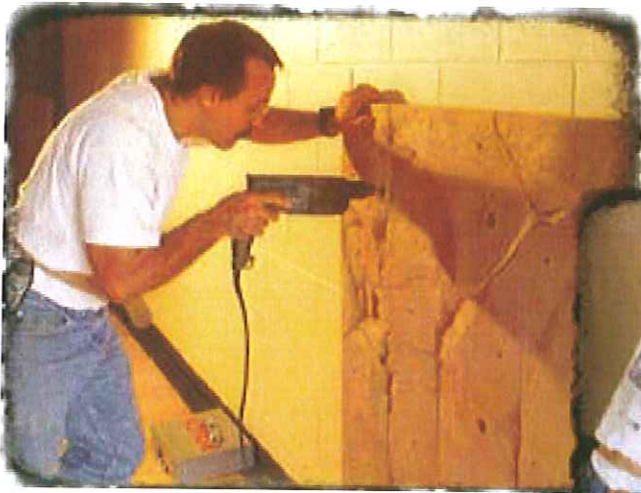

Pilot holes are drilled into the C.M.U. Block or poured concrete wall with a hammer drill.

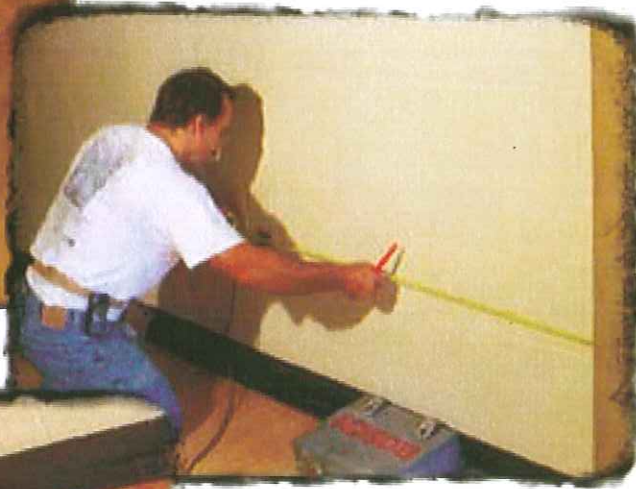

Measuring the location of the obstacle, such as an electrical outlet, allows for a nice, clean finished look.

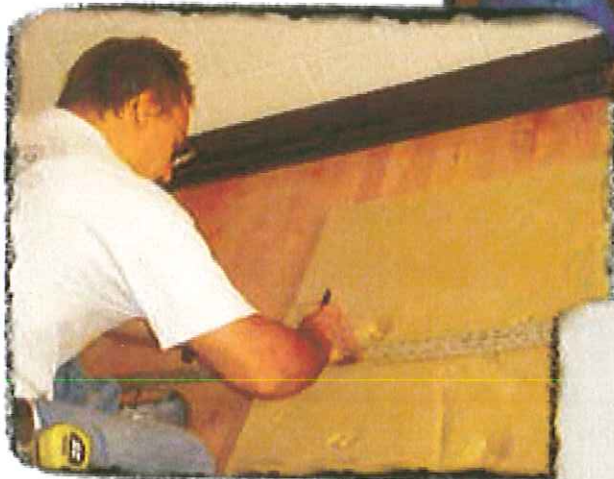

Standard woodworking tools can be used to trim a panel to fit, or to cut around any existing electrical outlets, switches, etc. to customize installations.



Panels are set in place and the holes are drilled. Final attachment is simple with the use of standard hand tools (e.g. socket wrench).

There are a number of different panel designs and each is usable in four different orientations. The edges, incuts, and micro-terrain of these panels are meant to be used by climbers for hand and footholds and were designed to be of a particular grade in each orientation. If placing a series of panels for use on a full-height climbing wall, "naturals" routes of various difficulties can be created – before handholds are even added to the wall!

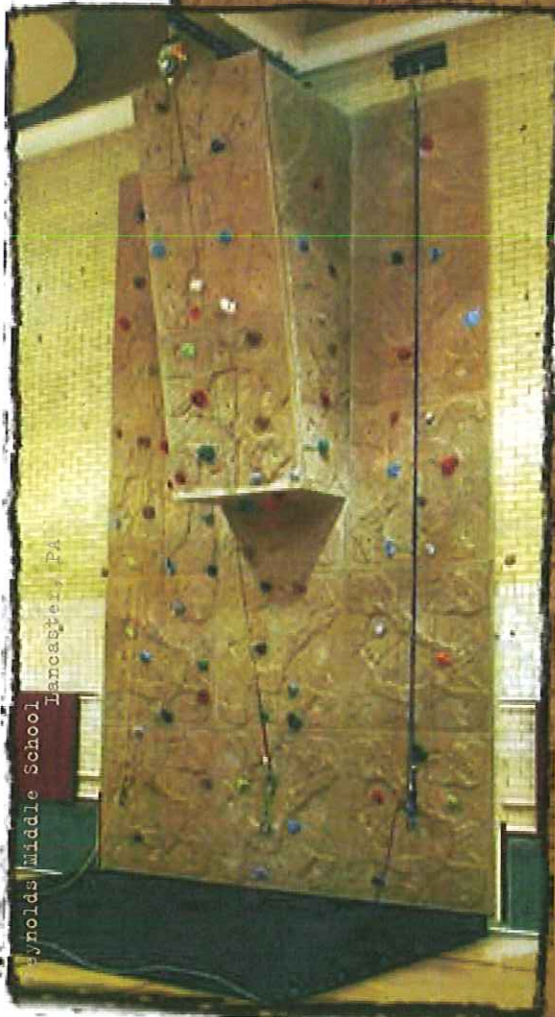

Arnolds Middle School  
Lancaster, PA

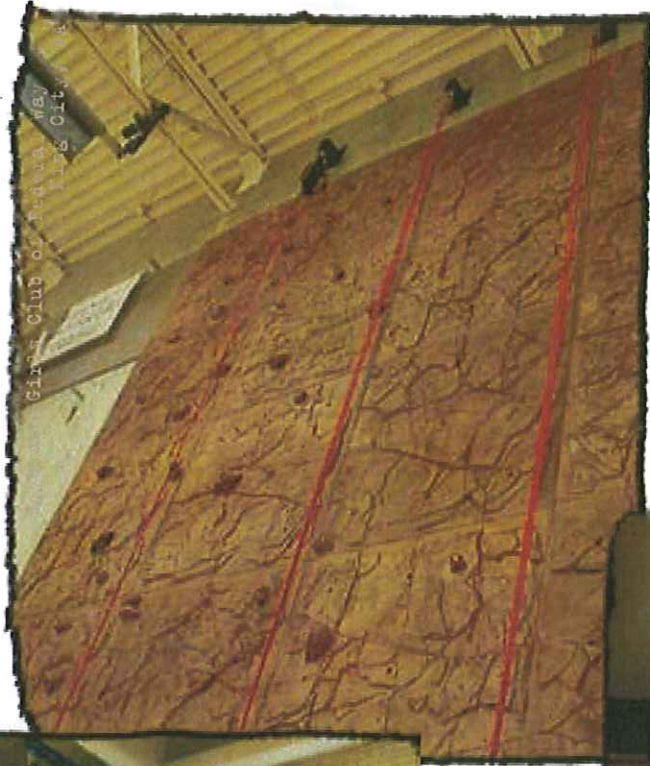

Star Club of the Way  
Lodge City

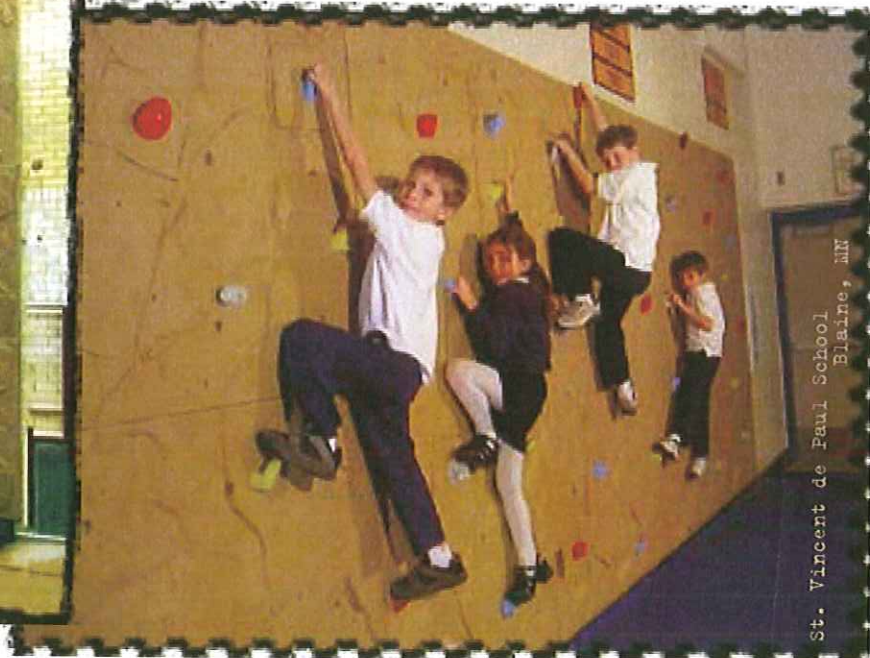
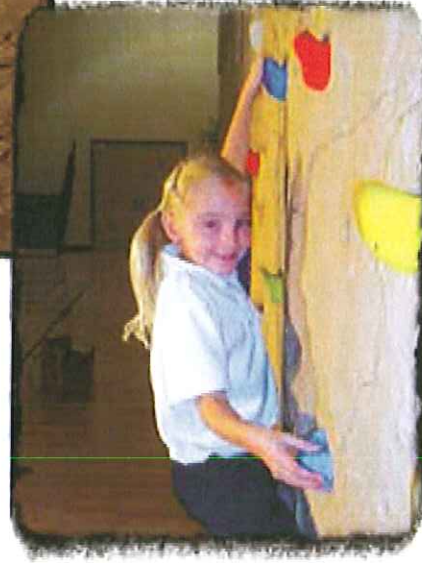

St. Vincent de Paul School  
Blaine, MN

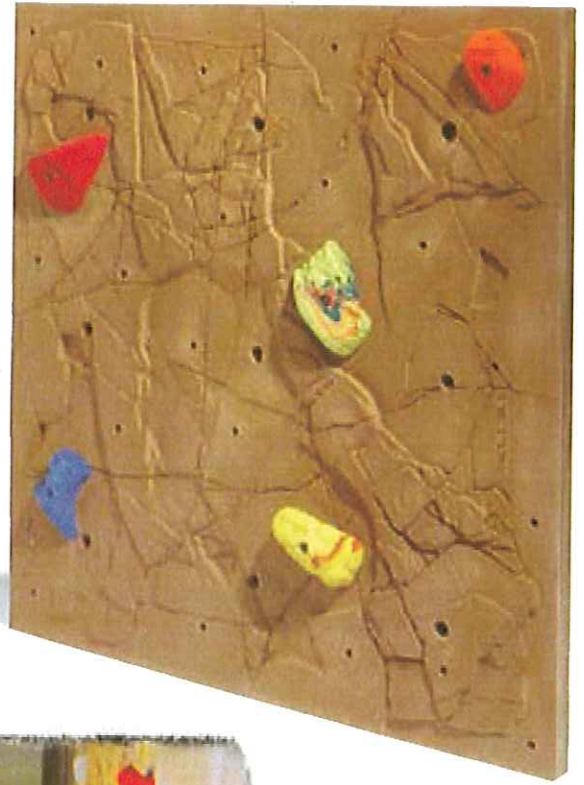

Nicros Climbing Walls  
651.778.1975  
www.nicros.com  
**20**  
(twenty nine)

# Nicros-EasyWall™

## SYSTEM DESCRIPTION

Nicros-EasyWall™ is a uniquely designed rock climbing wall panel system that is named "EasyWall" because installation is as easy as bolting it to an existing wall. Nicros-EasyWall™ is a light-weight 4'x4' rock climbing panel system that comes with handholds, mounting hardware, installation manual and is paint able.

## PRODUCT

### Panel:

- 48" x 48" with a +/-1/4" tolerance
- 45-50 lbs.
- Maximum 4" projection from back (zero) plane
- Rock-like look
- Dry "feel"
- Uniform texture
- Non-warping
- Defect free, internally and externally
- Thermal stability to minimum 180°
- UV resistant
- Shore D hardness > 40
- Edge return to the zero plane
- Edges of uniform thickness
- Hand tooling of material (cut to fit)

### Handhold Attachment Points (HAP):

- 22-28 HAP per panel
- HAP perpendicular to local orientation plane (2-8" diameter areas)
- HAP orientation planes variable
- HAP pull out load of minimum of 1300 lbf

### Anchoring Points:

- Back of anchor points at zero plane
- 16" center for anchor points with a +/-1/4" tolerance
- Anchor point pull-out load minimum of 1300 lbf

## FASTENERS

- 9 Hilti 14 X 3.25 Torx IHWH concrete screws with washers attach each panel to CMU walls
- 9 3/8 X 3 zinc plated lag screws with washers attach each panel to wood walls

## WARRANTY

A one year warranty is provided to the original purchaser ensuring the product is free from defects in material and workmanship.





## 15 CU. FT. CHEST FREEZER

## KCS150L



- Static Condenser**
- 1/3 HP Compressor**
- Painted Steel Exterior & Interior**
- Mechanical Control**
- Internal Temperature Display**
- Freezer Basket**
- Locking Lids & Key** Protect the contents of the unit
- Heavy Duty Casters**
- Interior Lighting**



### TECHNICAL SPECIFICATIONS

MODEL	KCS150L
Product Line	Chest Freezer
Capacity (Cu. Ft.)	14.9
Condenser Type	Static
Automatic Defrost Cooling System	No
Compressor Horsepower	1/3
Exterior Finish	Textured Painted Steel
Interior Finish	Painted Steel
Freezer Baskets (Number/Type)	1/Wire
Control	Mechanical
Temperature Display Location	Internal
Temperature Range	-15 to 10°F
Interior Lighting	Yes
Voltage Rating	120V/5A
Run Amps	1.3
Plug Type	NEMA 5-15P
Shipping Weight (Lbs.)	169
Warranty	3 Year/5 Year



#### NSF®-Certified Basket

Durable and reliable for safety in food storage.



#### NSF®-Certified Temperature Gauge

Durable and reliable for safety in food storage.



#### Heavy-Duty, Locking Casters

Keeps unit in place but allows position adjusting.



# 15 CU. FT. CHEST FREEZER

## KCS150L

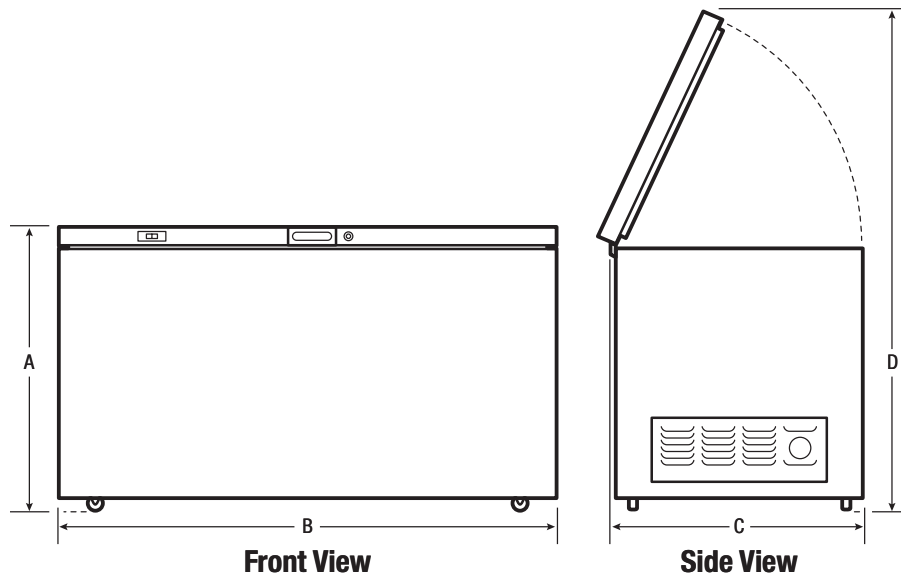

Plug Type (NEMA)  
5-15P

### EXTERIOR DIMENSIONS

Height <b>A</b> (Including Casters & Lid)	37-1/2"
Width <b>B</b>	48"
Cabinet Depth <b>C</b>	27-1/2"
Height (with Lid Open) <b>D</b>	60-13/16"

### CERTIFICATIONS AND APPROVALS

ENERGY STAR® Qualified	Yes
Safety Certification	CSA
Sanitation Certification	NSF®

### ACCESSORIES

Lock & Key	297090100
NSF® wire basket	297118601
Basket divider	296506200
NSF® thermometer	297070100

**Kelvinator**®

USA • 10200 David Taylor Drive • Charlotte, NC 28262 • 1-866-738-1640 • kelvinator.com  
CANADA • 5855 Terry Fox Way • Mississauga, ON L5V 3E4

KCS150L 11/13

© 2013 Electrolux Home Products, Inc.

High standards of quality at Electrolux Home Products, Inc. mean we are constantly working to improve our products. We reserve the right to change specifications or discontinue models without notice.



# BEVERAGE-AIR

3779 Champion Blvd., Winston-Salem, NC 27105  
1-888-845-9800 Fax# 1-336-245-6453  
<http://www.Beverage-Air.com>

**CUSTOMER'S CHOICE FOR A HOT LOCATION**  
**Tested & Certified to Ambient Class of 100°F**

**3 Year Parts/Labor Warranty**  
**Additional 2 Year Compressor Warranty**

## MARKETMAX™ MERCHANDISER SERIES—GLASS DOOR MERCHANDISER

Double section glass door merchandiser with lighted sign panel used for merchandising and storage of frozen food, frozen novelty items and cold product.

### CABINET CONSTRUCTION

Heavy duty construction includes white coated steel interior walls. Exterior finish is heavy-duty steel with a baked on durable coating. Choose from black or white finish. S/S exterior and black interior options are available.

Foamed-in-place CFC and HCFC-free polyurethane insulation.  
Modern, one-piece grille is easily removed for cleaning and servicing.

Refrigerators have double pane, lowE argon filled glass doors. Freezer models have heated triple pane glass. Inside and outside panes are tempered for added safety. Anti-microbial door handles are standard. Doors provide automatic hold-open feature.

Brightly lighted sign panel.

### SHELVING

Five (5) heavy duty epoxy coated wire shelves per section standard.  
Four (4) shelf clips included per shelf (field installed).  
Shelves are adjustable in ½" increments.

### ELECTRONIC CONTROL

Electronic thermostat with manual defrost button provides a digital display of cabinet temperatures, which includes status indicators and key pad for any necessary temperature adjustments.

### REFRIGERATION

Self-contained bottom mount refrigeration system. Expansion valve refrigerant control on freezer provides quick temperature pull down and reduces compressor run time—meaning reduced energy consumption. Includes automatic condensate disposal. Refrigerators utilize ozone friendly R134a refrigerant. Freezers utilize ozone friendly R404A refrigerant and its defrost system is fully automatic, time-initiated and temperature terminated operation.

Freezer product temperatures from -10°F to -15°F.  
Refrigerator product temperatures from 36°F to 38°F.

### ELECTRICAL

Interior fluorescent lighting enhances product illumination.  
Optional LED lighting provides hidden light source for increased product visibility. LED bulbs last up to 10 times longer compared to fluorescent bulbs and renders additional energy savings due to reduced wattage load on compressor.

Item No. \_\_\_\_\_  
Quantity \_\_\_\_\_

**HINGED GLASS DOOR  
MARKETMAX™  
MERCHANDISER SERIES**  
MM44 Refrigerator and Freezers  
Double Door

**MODELS:**  
MMR44-1-B  
MMR44-1-W  
MMR44-1-B-LED  
MMR44-1-W-LED  
MMF44-1-B  
MMF44-1-W  
MMF44-1-B-LED  
MMF44-1-W-LED



**MMR44-1-B**  
(SHOWN IN BLACK EXTERIOR)  
White and S/S Exterior  
finishes available



**MMF44-1-W**  
(SHOWN IN WHITE EXTERIOR)  
Black and S/S Exterior  
finishes available

### SPECIAL FEATURES

- MMR44 and MMF44 have earned the ENERGY STAR®
- Anti-microbial door handles
- Electronic control with digital display
- Brightly lighted sign panel
- Optional LED lighting
- **Available options:** S/S Exterior, Black Interior, Wine Racks, Spring Feed Dividers, Casters, Audible Alarm With PM Feature, Smart Defrost

### ELECTRICAL CONNECTION

Refrigerator units wired at factory and ready for connection to a 115/60/1 phase, 15 amp dedicated outlet. Freezer units wired at factory and ready for connection to a 115/60/1 phase, 20 amp dedicated outlet. 8' long cord and plug set included.



115/60/1  
NEMA-5-15P  
Refrigerator



115/60/1  
NEMA-5-20P  
Freezer

### ELECTRICAL CONNECTION

Units pre-wired at factory and include 8' long cord and plug set.



\*Note: Not all markings may apply to all model variations.

Available From:

Model Specified \_\_\_\_\_

Store# \_\_\_\_\_

Location \_\_\_\_\_

Quantity \_\_\_\_\_



**BEVERAGE-AIR**

**MarketMax™ Glass Door Merchandisers**

Model: MMR44, MMF44

MODEL	MMR44	MMF44
<b>EXTERNAL DIMENSIONAL DATA</b>		
Length Overall (inches)	47"	47"
Length Overall (mm)	1194	1194
Depth Overall (inches) - includes handle	33 3/4"	33 3/4"
Depth Overall (mm) - includes handle	857	857
Height Overall— (inches)	78"	78"
Height Overall— (mm)	1981	1981
Number of doors	2	2
Depth with Door Open 90 °	60"	60"
<b>INTERNAL DIMENSIONAL DATA</b>		
NET Capacity (cubic ft.)	45	45
NET Capacity (Liters)	1274	1274
Internal Length Overall (inches)	44"	44"
Internal Length Overall (mm)	1118	1118
Internal Depth Overall (inches)	28 1/2"	28 1/2"
Internal Depth Overall (mm)	724	724
Internal Height Overall—(inches)	61 3/4"	61 3/4"
Internal Height Overall—(mm)	1569	1569
Number of shelves	10	10
<b>ELECTRICAL DATA</b>		
Full Load Amperes 115/60/1	8.8 A	13.8 A
<b>REFRIGERATION DATA</b>		
Horsepower	1/3	3/4
<b>WEIGHT DATA</b>		
Gross Weight (Crated lbs)	530	560
Gross Weight (Crated kg)	240	254

**PLAN VIEWS**

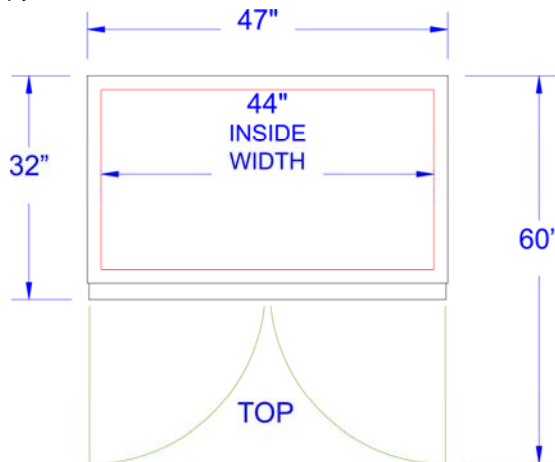
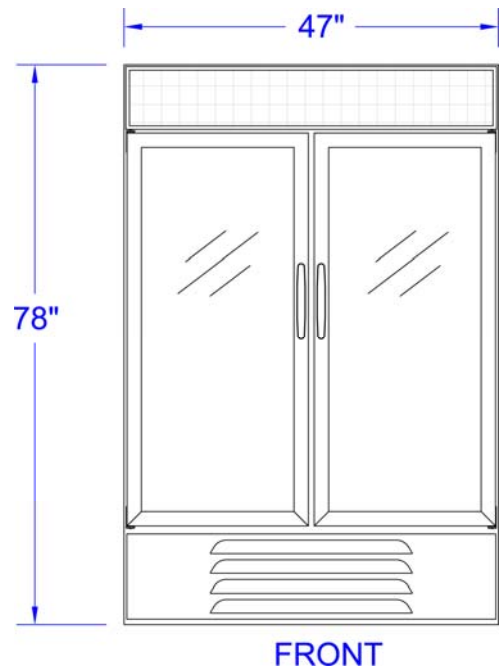
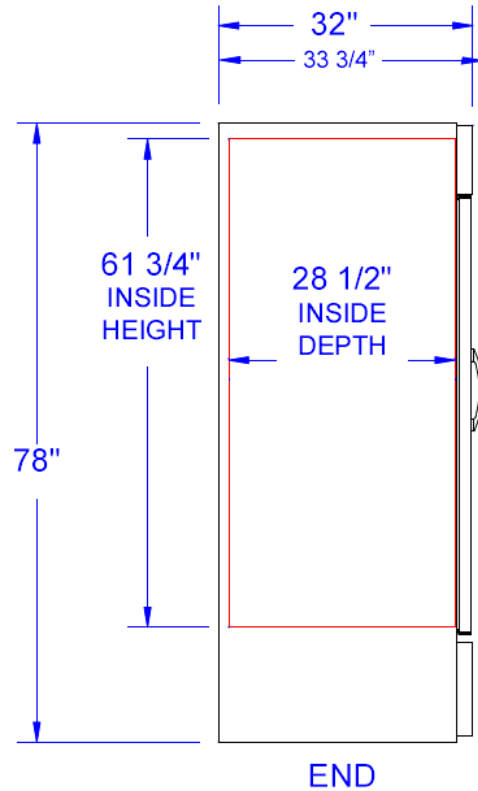

Note: Not all markings may apply to all model variations.

**BEVERAGE-AIR® CORPORATION**

3779 Champion Blvd. • Winston-Salem, NC 27105 USA • (336) 245-6400 • Fax (336) 245-6453 • (888) 845-9800 • www.beverage-air.com

Specifications are subject to change without prior notice. 06/13

[Financing](#)[Live Chat or Call](#)[Available Contracts](#)[Coupons](#)

## Dell Color Printer - C1760nw with 1-Year ProSupport Warranty



Experience excellent print quality and reliable printing with Dell™ C1760nw Color Printer. Get professional business quality prints with crisp text and sharp images, up to 600 x 600 dpi resolution. Performing ... [Full Description](#)

**Dell Price**..... **\$507.95**

[Add to Cart](#)

Usually Ships: Within 1-2 business days

Manufacturer Part# : 00001 | Dell Part# : DFS1760

[Overview](#)[Tech Specs](#)

### Highlights

- Offers printing speed of up to 15 ppm mono and up to 12 ppm color
- Equipped with 384 MHz processor speed
- Incorporates 128 MB memory
- Offers high-volume print capacity with a maximum duty cycle of 30,000 pages per month
- Delivers professional business quality prints with up to 600 x 600 dpi resolution
- Contains a high-input 150-sheet paper tray

### Overview

Experience excellent print quality and reliable printing with Dell™ C1760nw Color Printer. Get professional business quality prints with crisp text and sharp images, up to 600 x 600 dpi resolution. Performing efficiently at print speeds of up to 15 pages per minute (ppm) mono and 12 pages per minute (ppm) color (Letter Size / A4) the C1760nw can reliably produce high quality printing at a maximum monthly duty cycle of up to 30,000 pages. Also, it features a small intelligent self-scanning print head and enhanced imaging controller, with low maintenance. Additionally, built-in Ethernet and Wi-Fi connectivity enables shared use of this printer among multiple users and extends greater value and savings.

Furthermore, get the excellent print quality and reliable printing using a four-row LCD display with 34 buttons and five LED indicators. It is equipped with LED printing technology which delivers superior print quality, lower energy consumption and maintenance-free performance. Also, this printer is Energy Star® certified, making it more power efficient than conventional models and lets you print vivid, bright and vibrant printouts with ease. This product has been tested and validated on Dell systems. It is supported by Dell Technical Support when used with a Dell system.

Manufacturer Part# : 00001  
Dell Part# : DFS1760

© 2015 Dell

[Regulatory Compliance](#)

[Terms of Sale](#)

[Unresolved Issues](#)

[Privacy](#)

[Ads & Emails](#)

[Dell Recycling](#)

[Contact](#)

[Site Map](#)

[Visit ID](#)

[Feedback](#)

[Products](#) ▼

Offers subject to change, not combinable with all other offers. Taxes, shipping, handling and other fees apply. U.S. Dell Small Business new purchases only. LIMIT 5 DISCOUNTED OR PROMOTIONAL ITEMS PER CUSTOMER. Dell reserves right to cancel orders arising from pricing or other errors.